

MOTION SENSOR FOR SURFACE MOUNTING

MODEL: SDOM

INSTRUCTIONS FOR EXPLOITATION

The installation should be performed by a qualified electrician according to this manual.
Please keep the instructions.

PRODUCT CHARACTERISTICS

Detection Range:	360°
Power supply:	220V-240V AC/ 50-60Hz
Max rated load:	2000W (incandescent lamps) 1000W (energy saving lamps)
Detection distance:	max. 5m
Installation height:	2.2~4m
Working temperature range:	-20°C~+40°C
Time delay:	min. 10sec±3sec (adjustable) max. 15min±2 min (adjustable)
Ambient light:	<3-2000 lx (adjustable)
Index of protection:	IP20
Power consumption:	0.5W
Working humidity:	< 93%RH
Detection moving speed:	0.6-1.5m/s

NOTES AND INFORMATION

The motion sensor SDOM is a passive infrared sensor, which detects (monitors) infrared rays (warmth) emitted by the objects that fall into its detection range. The sensor turns on / off the load, connected to it, depending on the change of the thermal background in the detection area. This is why it is not recommended to install the motion sensor SDOM in areas with great temperature amplitude – near air conditioners or heaters. Infrared sensors are normally used as motion sensors.

SAFETY INSTRUCTIONS

Any action performed when the main power supply is on has a risk of electrical shock. The power supply must be turned off prior to installation. The max. load should not be exceeded. It is not recommended to use the sensor to control luminescent lamps. The sensor is designed to be installed in vertical position on still surfaces.

INSTALLATION

1. Turn off the main power supply.
2. Turn the upper cover anti-clockwise according to the diagram on the right.
3. Pull the power cable through the hole of the base.
4. Connect according to the scheme below.
5. Fix the base on a suitable place.
6. Install back the upper cover on the sensor

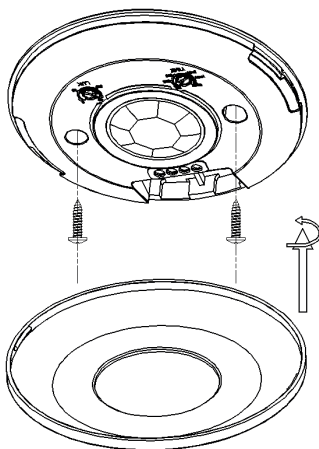

CONNECTION-WIRE DIAGRAM

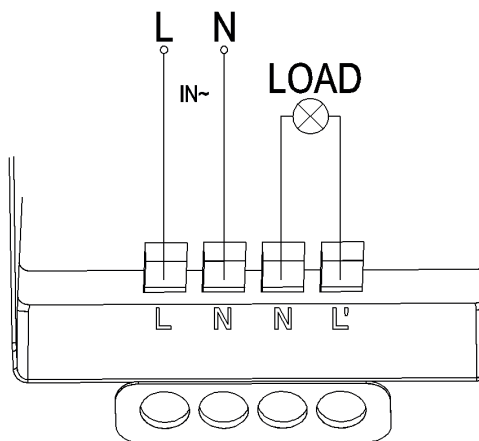

Connection-wire diagram

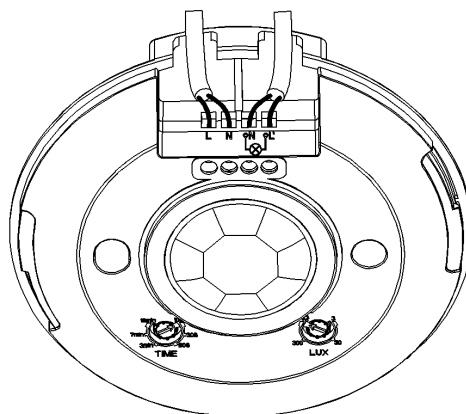

The wires come in and out from the side

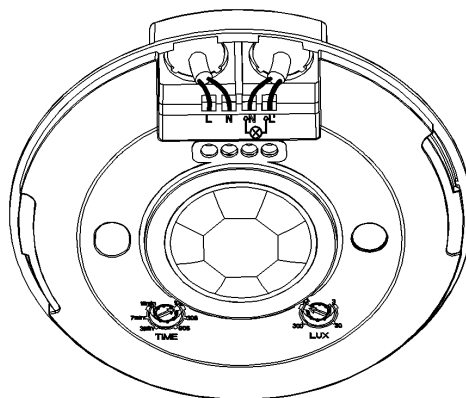

The wires come in and out from bottom

TESTING THE SENSOR

- Before switching the main power supply on, turn TIME knob anticlockwise to "10s" and the LUX knob clockwise to the symbol "sun".
- Turn on the power supply and the lights will immediately turn on. 10 seconds \pm 3 sec. later, the lights will turn off automatically. If the sensor detects a moving object, it will work again normally.
- If a movement is detected in the controlled area, the sensor will turn on the load. If a movement is detected again during the time delay, the time will be recalculated based on the initial settings.
- To test the sensor sensitivity to ambient light, turn LUX knob anticlockwise to the symbol "3". If the ambient light is more than 3lx, the sensor will turn off the load, even if there is a movement in the detection area. If the ambient light is less 3lx, the sensor will turn on the load, once detecting a moving object.
- If the sensor is covered with a cloth or other non-transparent material, the lamp will be switched on and switched off after 10 seconds (\pm 3 sec)
- If each lamp is 60W, the distance between the sensor and the nearest lamp has to be more than 60 cm.

SOME PROBLEM AND SOLVED WAY

The lamp does not turn on:

- Please check if the power and load connection is correct.
- Make sure the lamp is not defective.
- Check if the working light corresponds to the ambient light.
- When testing in daylight, please turn LUX knob to „sun“ position, otherwise the sensor lamp could not work!

The sensitivity is poor:

- Please check if there is hinder in front of the detection window to prevent from receiving the signals.
- Please check if the ambient temperature is too high.
- Please check if the signals source is in the detection area.
- Please check if the installation height corresponds to the height shown in the instruction.
- Please check if the moving orientation is correct.

The sensor doesn't switch off the load automatically:

- Check if there are continual signals in the detection area.
- Make sure TIME knob is not set to "15min".
- Check if the power corresponds to the instruction.
- Make sure there are no heaters in the sensor range.

TAKING CARE OF THE NATURAL ENVIRONMENT CLEANLINESS

The product and its components are not harmful to the environment
Please dispose the package elements separately in containers for the corresponding material.



Please dispose the broken product separately in containers for out of usage electrical equipment.